

pul

pulcollekt_LD1

Non-Adjustable – Pre-Sealed

PUL Collekt_LD1 Installation Instructions and Owner's Manual

SUBMERGED SUCTION OUTLET FOR INSTALLATION AS A SINGLE UNBLOCKABLE DRAIN OR IN A MULTI-DRAIN SYSTEM

MAXIMUM FLOW – **256 GPM FLOOR & WALL**
THE TOTAL SYSTEM FLOW (GPM) SHALL NEVER EXCEED THE MAXIMUM CERTIFIED FLOW RATING.

This Drain (Part # 2205-00001A-01-xx (1)(2)) is certified by IAPMO R&T to meet or exceed all requirements of the Virginia Graeme Baker Pool and Spa Safety Act ANSI/APSP 16 – 2017 (PA 2021).



Certification testing performed by IAPMO R&T Lab: Test Report # 3679-24001.

1. XX = DG for dark grey or W for white
2. Model numbers can be represented as CLD-BO-01-DG or CLD-BO-01-W.

ATTENTION

Installers must read and follow these instructions. Once complete provide these instructions to the facility owner to keep for further reference. Follow all codes and regulations that apply to the design, installation, and use of suction outlet fittings.

WARNING

The PUL Products Collekt LD1 Drain System must be installed in accordance with PUL's written instructions manual, and in conformity with applicable Federal, State, Local, and Swimming pool industry building and safety codes.

PUL Products LLC – 503 E Watkins St – Phoenix, AZ 85004

Phone: (833) 922 – 2418

info@pulproducts.com – www.pulproducts.com

US & Foreign patents and patents pending see www.pulproducts.com/about/patents/.

pulcollekt_LD 1

IMPORTANT SAFETY INSTRUCTIONS: PLEASE REVIEW THE OWNER'S MANUAL AND INSTALLATION INSTRUCTIONS IN ITS ENTIRETY AND HEED ALL SAFETY INFORMATION. Failure to follow these instructions and warnings can result in DEATH OR SERIOUS INJURY. **ANY DEVIATION FROM THE INSTRUCTIONS DEFINED HERE OR MODIFICATION OF THE DRAIN ITSELF WILL VOID THE DRAINS SAFETY CERTIFICATION.**

SUCTION ENTRAPMENT HAZARD:

DEATH or SERIOUS INJURY can result if a drain cover or grate is not installed and used correctly.

- Pool & spa pumps produce high levels of suction and move high volumes of water, which can cause death or serious injury if a person comes in close proximity to pool or spa drains.
- Keep clear of pool and spa drains to avoid death or serious injury from suction.

HAIR ENTRAPMENT: Hair can become entangled in a suction outlet.

LIMB ENTRAPMENT: Any limb inserted into a suction outlet sump or cover that is broken, cracked, missing, or not securely/properly installed can result in a mechanical bind or swelling of the limb.

BODY ENTRAPMENT: A suction applied to a large portion of a body can result in entrapment.

MECHANICAL ENTRAPMENT: An item that is attached to or around your body (e.g. swimsuit, necklace, hair extension/decoration, fingers/toes, etc.) that becomes caught in a suction outlet opening could result in mechanical entrapment.

DISEMBOWELMENT/EVISCERATION: Avoid sitting directly on any suction outlet. The suction created can cause severe intestinal damage.

MAINTENANCE INSTRUCTIONS & WARNINGS:

DEATH or SERIOUS INJURY can result from pool or spa drain covers or grates that are clogged by debris.

- All pool and spa drain covers may become obstructed by debris and should be cleaned periodically due to clogging from debris, such as pieces of plastic, hair, fabric, twigs, leaves, seeds, etc.
- Clogging of the drain cover will increase the suction effect and increase the likelihood of death or serious injury from the hazards listed above.
- A clogged drain can negatively affect the safety of the drain.

DEATH or SERIOUS INJURY will result if a pool or spa drain cover or grate is not installed, missing, or broken.

- Inspect the drain, including fasteners, each operational day for damage or tampering to ensure that the drain covers/grates and fasteners are properly in place and secured.
- Ensure that the drain covers are not discolored, damaged, cracked, broken, brittle, loose, clogged, improperly secured, or missing. These conditions increase the chance of death or serious injury from entrapment.
- If the drain cover or interior finish securing the drain to the pool shell is found to be damaged, cracked, broken, loose, clogged, improperly secured, or missing, you should:
 - **CLOSE THE POOL OR SPA IMMEDIATELY;** and,
 - Post a closure notice and keep the pool or spa closed until an appropriate ANSI/APSP -16-2011 certified drain cover is properly installed.
- No modification shall be made to a SOFA structure or flow path unless the new configuration has been certified as new SOFA.
- The drain shall never be located on seats or backrest for seats.
- Any system modification that increases the flow rate of the circulation system shall require reevaluation of the drain system to ensure that the maximum flow rating is not exceeded.
- **READ, FOLLOW, AND UNDERSTAND ALL INSTRUCTIONS AND WARNINGS – SAVE THESE INSTRUCTIONS!**

pulcollekt_LD1

INCLUDED COMPONENTS

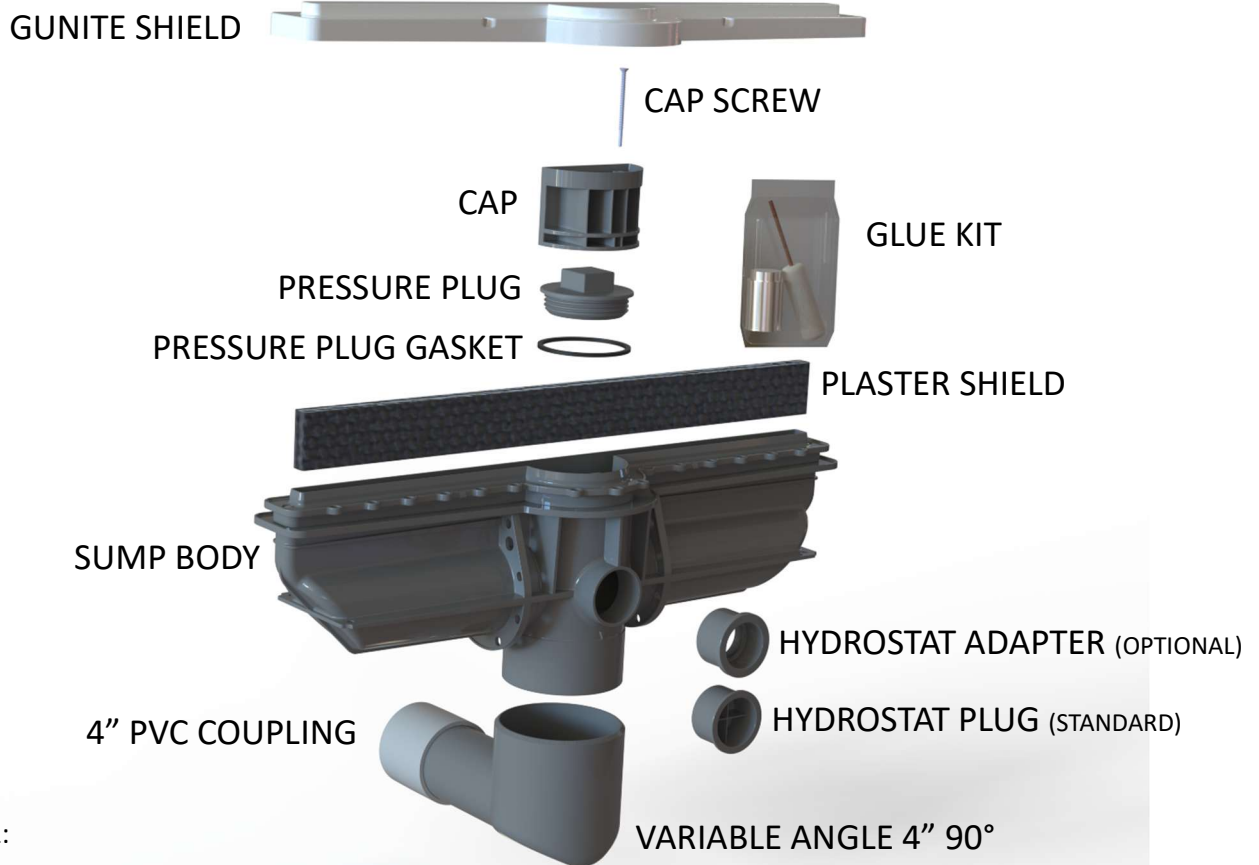

Figure 1:

DESCRIPTION	PART #
COMPLETE DRAIN ASSEMBLY	2205-00001A-01
GUNITE SHIELD	2205-20013A-01
CAP SCREW	2205-80002A-01
FLIP CAP	2205-20007A-01
PRESSURE PLUG	2205-20009A-01
PRESSURE PLUG GASKET	2205-40018A-01
PLASTER SHIELD	2205-20017A-01
HYDROSTAT ADAPTER	2205-20005A-01
HYDROSTAT PLUG	2205-20014A-01
VARIABLE ANGLE 4" 90°	2205-20015A-01
GLUE KIT	2205-80023A-01

Service Life: 20 Years - PULcollekt_LD1 drain components must be replaced within this timeframe. Service life begins the month & year the drain was installed with or without water.

pulcollekt_LD1

DRAIN DIMENSIONS:

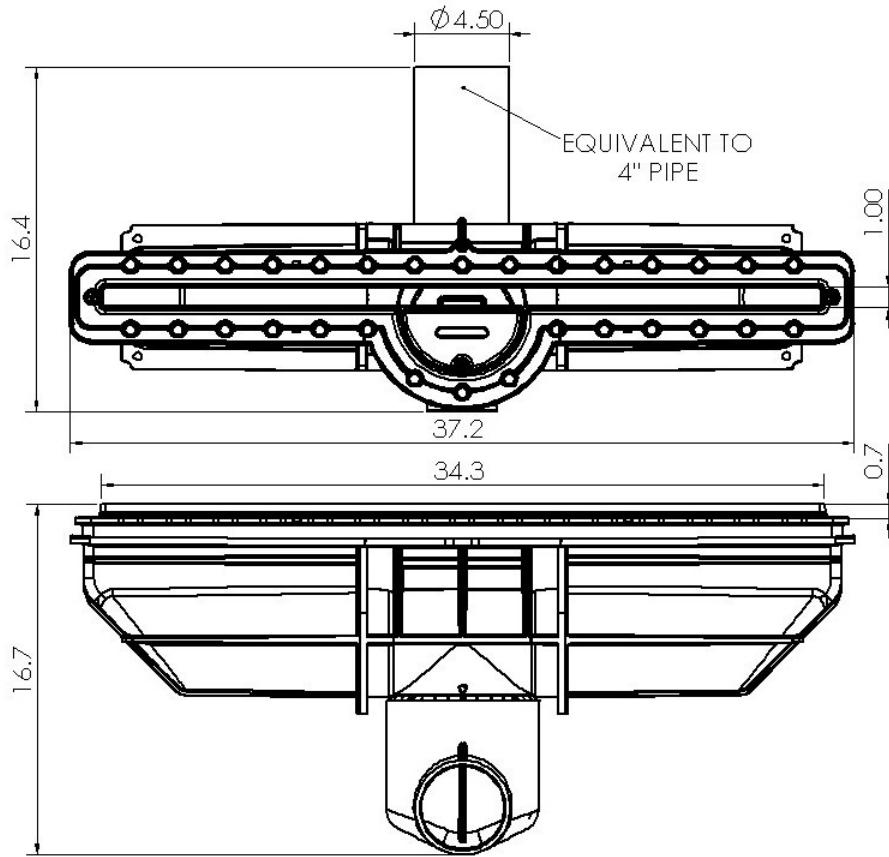

Figure 2:

HEAD LOSS CURVE:

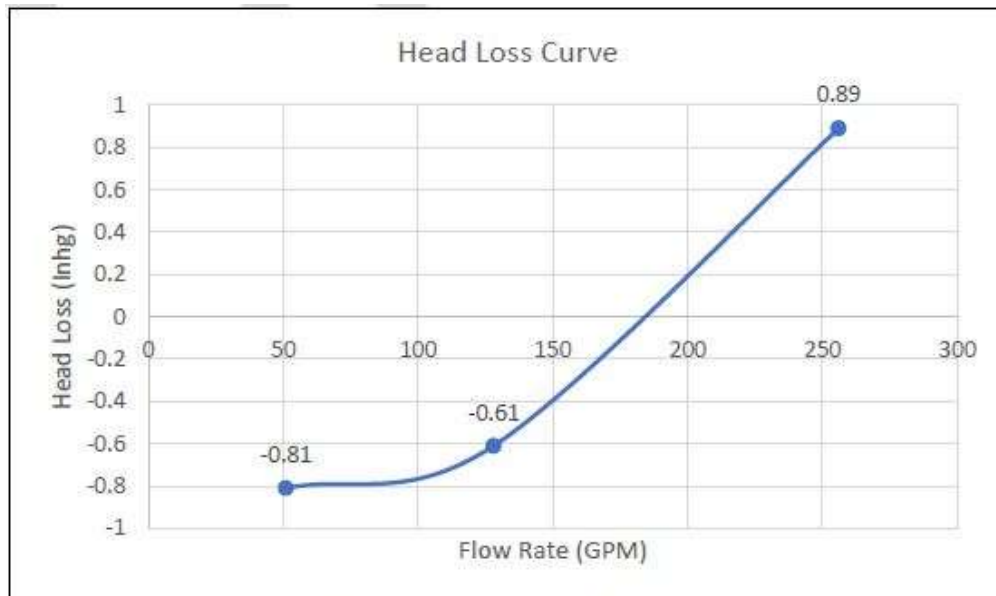

Figure 3:

Figure 1 – Head Loss Curve, SOFA model PUL Collekt_LD1

pulcollekt_LD1

INSTALLATION:

The PUL Collekt LD1 Drain has been certified to be in full compliance with VGB safety requirements and is only available to certified contractors.

Installation of PUL Products Collekt LD1 Drain System must be performed by a properly trained certified contractor following the exact installation instructions defined in this document.

The PUL Collekt LD1 drain is certified as an **"UNBLOCKABLE"** and therefore can be installed as a **SINGLE SUCTION OUTLET**, no other suction fittings are required.

The top surface of the PUL Collekt LD1 defines the bottom of the pool's interior finish and should be located in the center of the lowest point in the pool.

ATTENTION:

This unit has had the Waterproof Sealant, shown in Fig.4 preinstalled at our factory. This unit does not have an adjustable Upper Grate.

Care must be taken to ensure that the entire drain assembly is fully packed on all sides with Gunite to provide proper sealing and support. Fully pack in the entire drain with Gunite up to 1" below the Gunite Flange & fully pack Waterproof Sealant (Hydraulic Cement or similar) from the underside of the Gunite Flange to the underside of the Water Stop as shown in Fig.4 Below.

Failure to properly pack in this material may result in leaks and/or failure of the interior finish

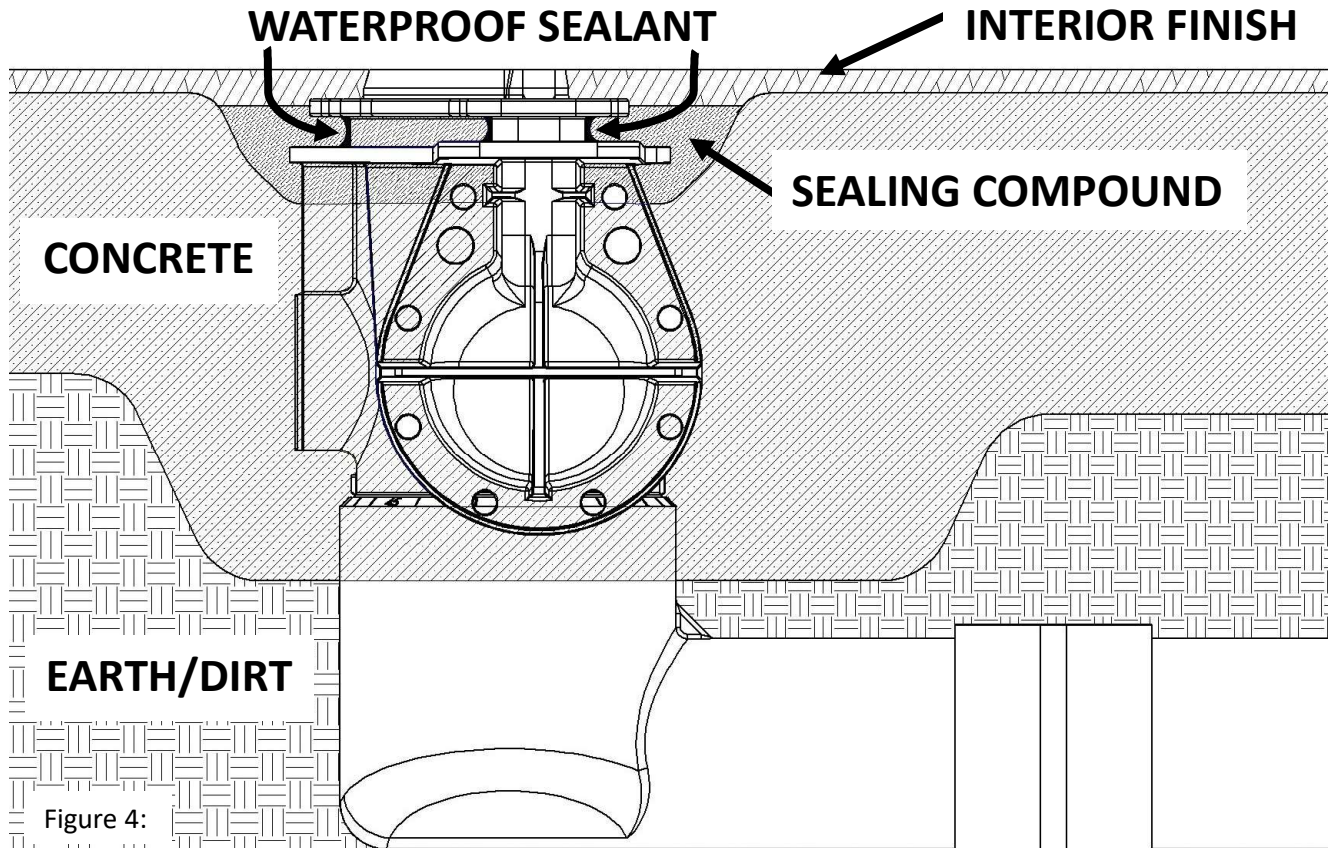

Figure 4:

FASTENERS:

All fasteners included with the PUL Collekt LD1 drain come preinstalled into the drain assembly. Only the supplied fasteners should be used. Use of any alternate fasteners is prohibited.

START ALL FASTENERS BY HAND TO ENSURE PROPER THREAD ENGAGEMENT

DO NOT USE POWER TOOLS – HAND TOOLS ONLY

Removal of fasteners during pressure plug removal or winterization is acceptable but only the original or manufacturer supplied replacement fasteners may be used during reinstallation.

The **use of adhesives** to secure or repair any portion of the Collekt drain **is strictly prohibited.**

pulcollekt_LD1

HYDROSTATIC RELIEF VALVE

Each PUL Collekt_LD1 sump is shipped with the ability to be installed either with or without a 2" hydrostatic relief valve.

CAUTION: The port on the side of the sump is provided for the installation of a **hydrostatic relief valve only!** **NEVER CONNECT THIS PORT TO PUMP SUCTION, DOING SO WILL VOID THE SAFETY CERTIFICATION OF THIS DRAIN SYSTEM.**

This port is **not** a standard pipe fitting size and will only work with either the provided plug or hydrostat adapter. **The ABS-to-ABS Cement/Glue REQUIRED for this connection is provided with each drain.**

If **no hydrostatic relief valve** is required, the installer **must glue the hydrostat plug into the sump** prior to drain installation (**Fig. 5**).

For pools requiring hydrostatic relief, the provided adapter must be glued into the side port (**Fig. 6**).

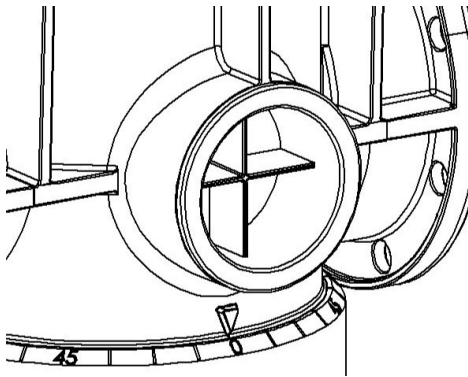

Figure 5:

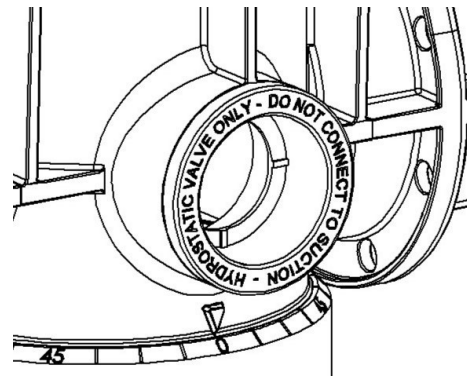

Figure 6:

If a hydrostatic relief valve is installed, **use an ABS-PVC Cement** to glue the hydrostat plumbing into the adapter and use a 90° fitting to route to a perforated pipe and gravel leach pit as shown in **Figure 7**.

Exception: The 2" Hydrostatic Port may be used as a return connection to the drain sump (Pressure side of Pump).

CAUTION: Under no circumstances is the Hydrostatic Port to be used as a suction fitting this voids the safety certifications and may cause severe injury or death.

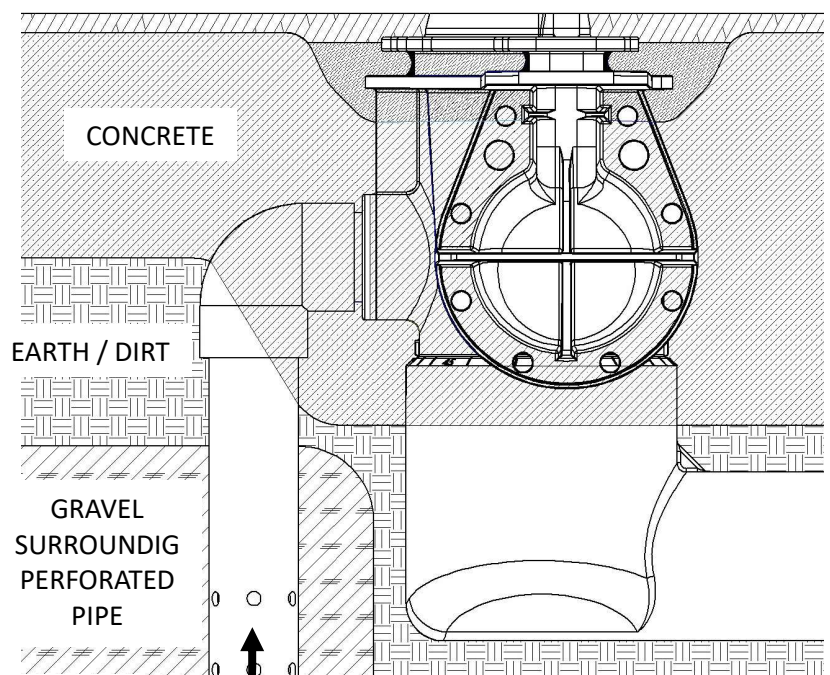

Figure 7:

pulcollekt_LD1

VARIABLE ANGLE LOWER 90°

The PULCollekt_LD1 is delivered with the Lower 4" 90° fitting unassembled. This allows the installer to adjust the direction of the suction line 360° while keeping the drain opening square to the edge of the pool as shown.

Aiming the 4" outlet at the point in the pool wall where the suction line exits the pool will minimize pipe run & the number of angled fittings required.

The medium bodied ABS-to-ABS Specific Cement/Glue REQUIRED for this connection is included with each drain.

***Make sure to keep the sump vertical during the gluing process to avoid pooling of glue and damage to the pressure plug threads.**

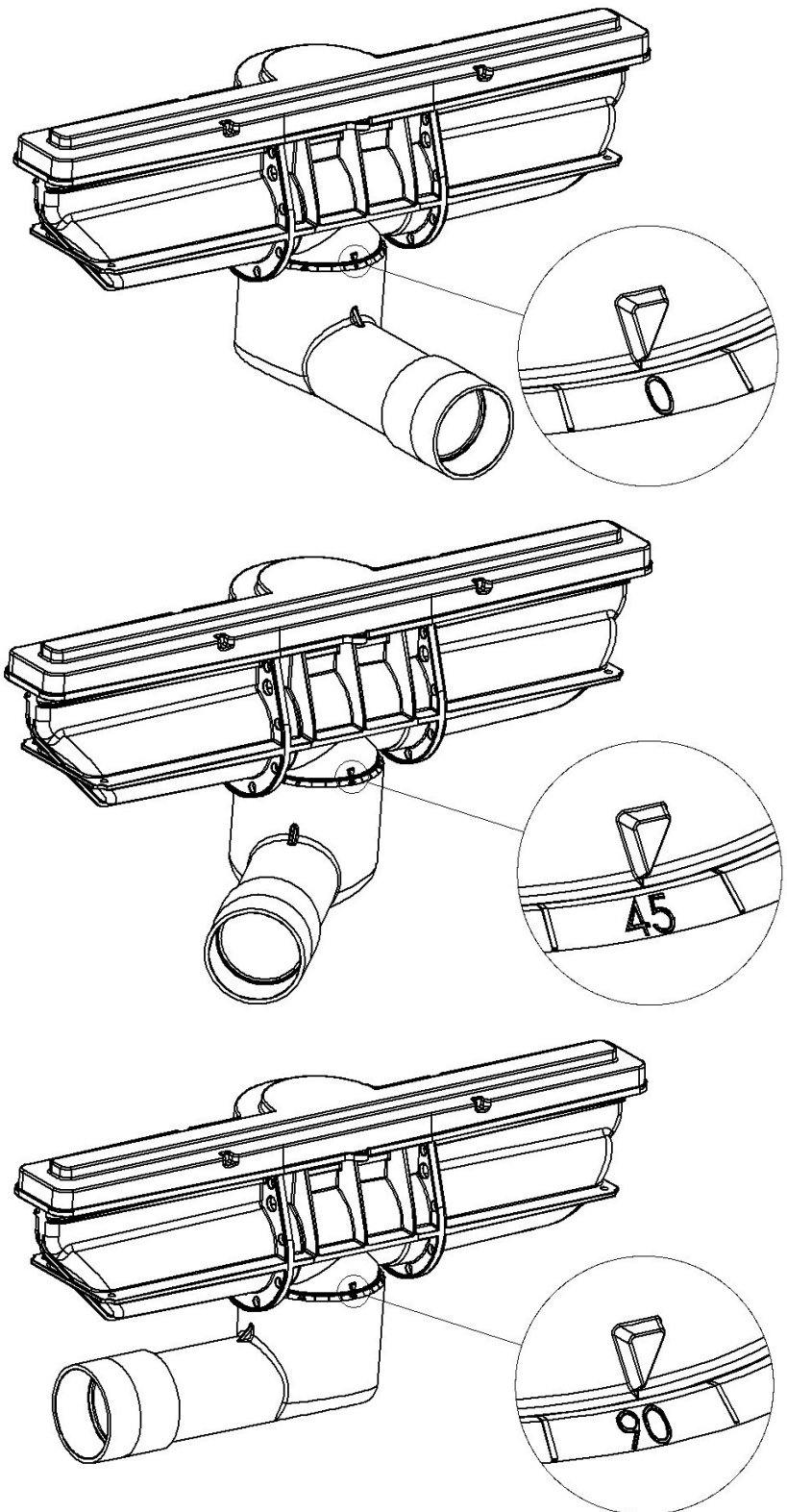

Figure 8:

EXCAVATION & CONNECTING TO PLUMBING

Identify the location of the drain in the bottom of the pool, excavate the drain location to provide space for the drain & suction line.

The upper edge of the drain will determine the depth of the pool and the final location of the interior finish. Verify that the drain is level in the excavated area using the bubble level included with each sump.

(Fig.9)

Connect the suction side plumbing, backfill the plumbing trench and pack the dirt around the lower 90 fitting to secure the drain and maintain level. **(Fig.10)**

Each Drain assembly is supplied with a 4" PVC coupling preinstalled. (Fig. 9)
Standard PVC-PVC Cement is required for this connection

The plumbing size is not to exceed 4".
Smaller plumbing diameter is acceptable assuming internal water velocity of the pipe does not exceed local code.

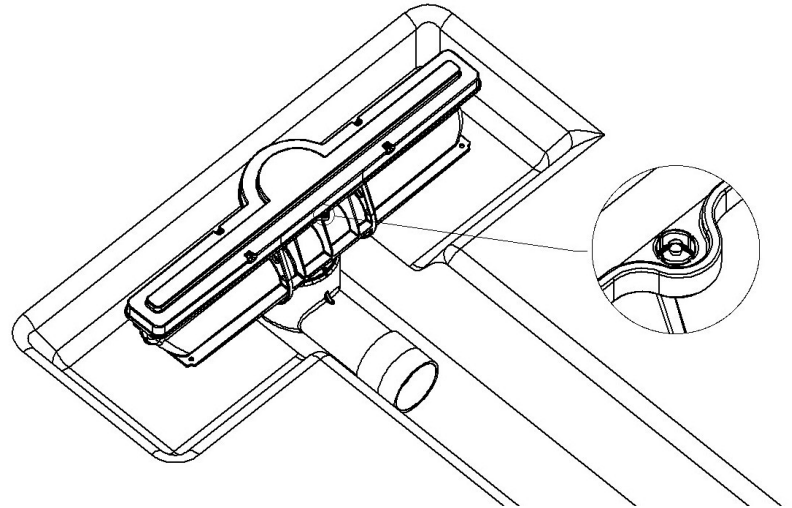

Figure 9:

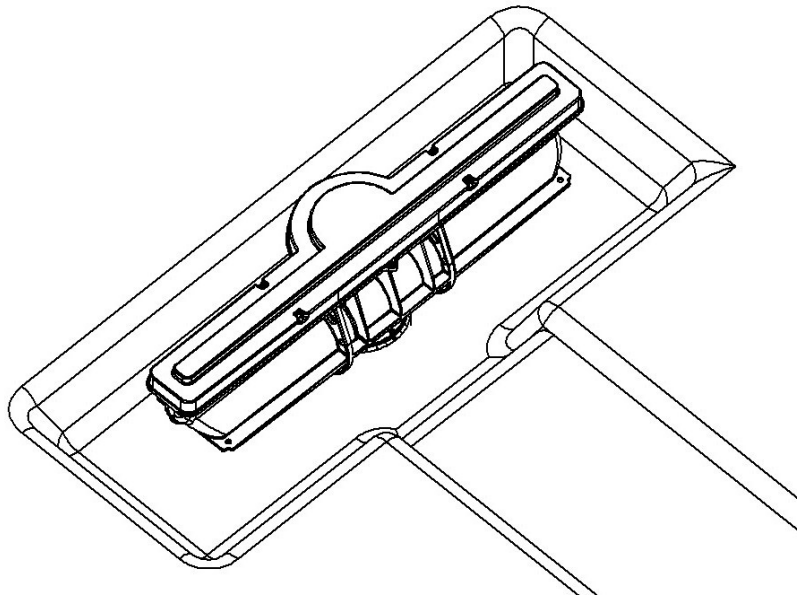

Figure 10:

pulcollekt_LD1

REBAR INSTALLATION & DRAIN TIE-IN

Lay the pool's rebar cage into the floor of the pool as normal. The rebar must be bent into a basket shape and routed below & around the drain. (**Fig. 11**)

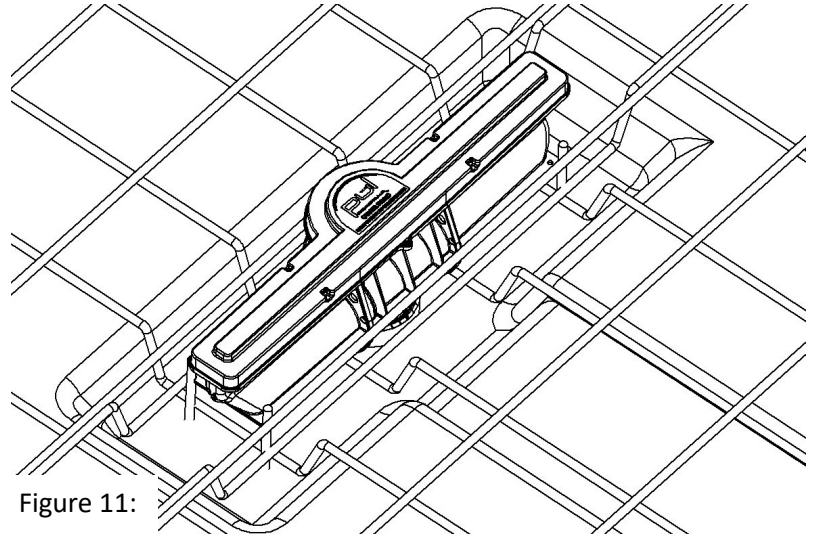

Figure 11:

The cage should be located halfway between the dirt excavation and the bottom of the sump. (**Fig. 12**)

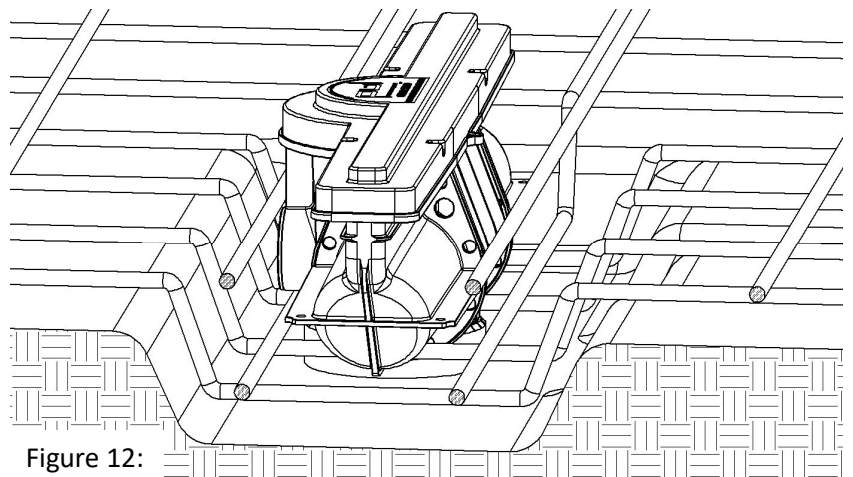

Figure 12:

pulcollekt_LD1

GUNITE / SHOTCRETE INSTALLATION

Shoot the concrete shell of the pool as normal making sure to fill all voids surrounding the drain and rebar cage.

The concrete should finish to approximately $\frac{1}{2}$ inch below the upper edge of the drain opening. (**Fig. 13**)

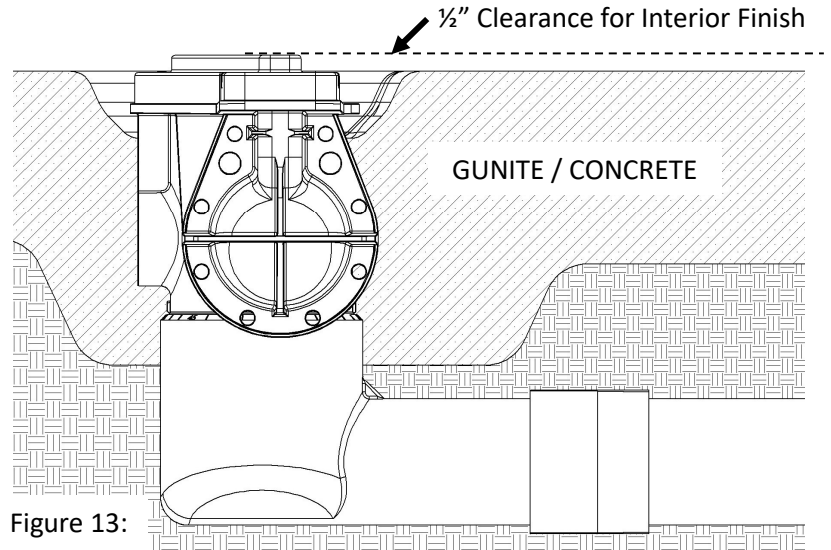

Figure 13:

Following concrete installation provide clearance around the entire Gunite Shield. The installer should be able to fit a finger between the Gunite Flange and the concrete down to 1" below & under the Gunite Flange as shown. (**Fig. 14**)

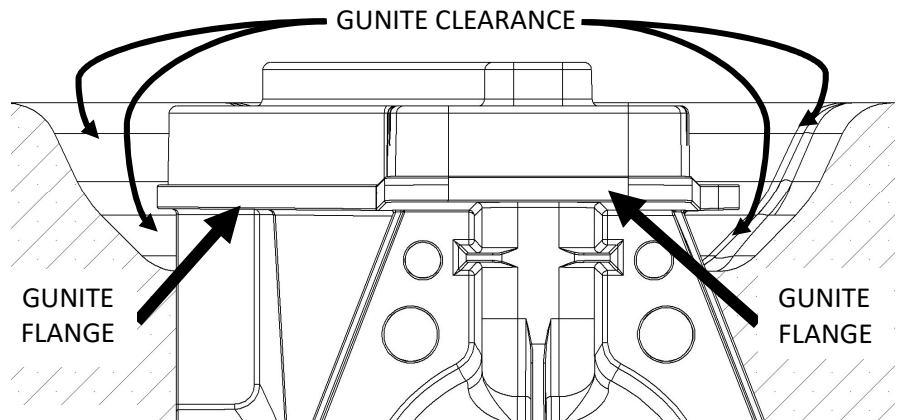

Figure 14:

Providing sufficient clearance is critical for proper sealing of the drain, removal of the Gunite Shield and final trim adjustment prior to interior finish installation. (**Fig. 15**)

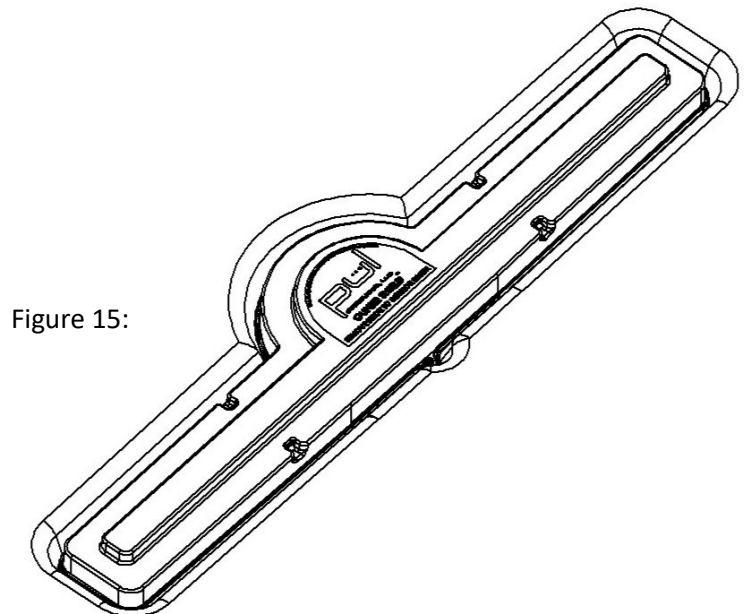

Figure 15:

pulcollekt_LD1

SEALING COMPOUND

This unit has had the Waterproof Sealant, shown in Fig.4 preinstalled at our factory. This unit does not have an adjustable Upper Grate

Use an approved sealing compound to fill the space below the Water Stop and Gunite Flange.

Ensure that all the space below the Gunite Flange and Water Stop are tightly packed without any voids (As shown) to ensure a water-tight seal. (**Fig. 16**)

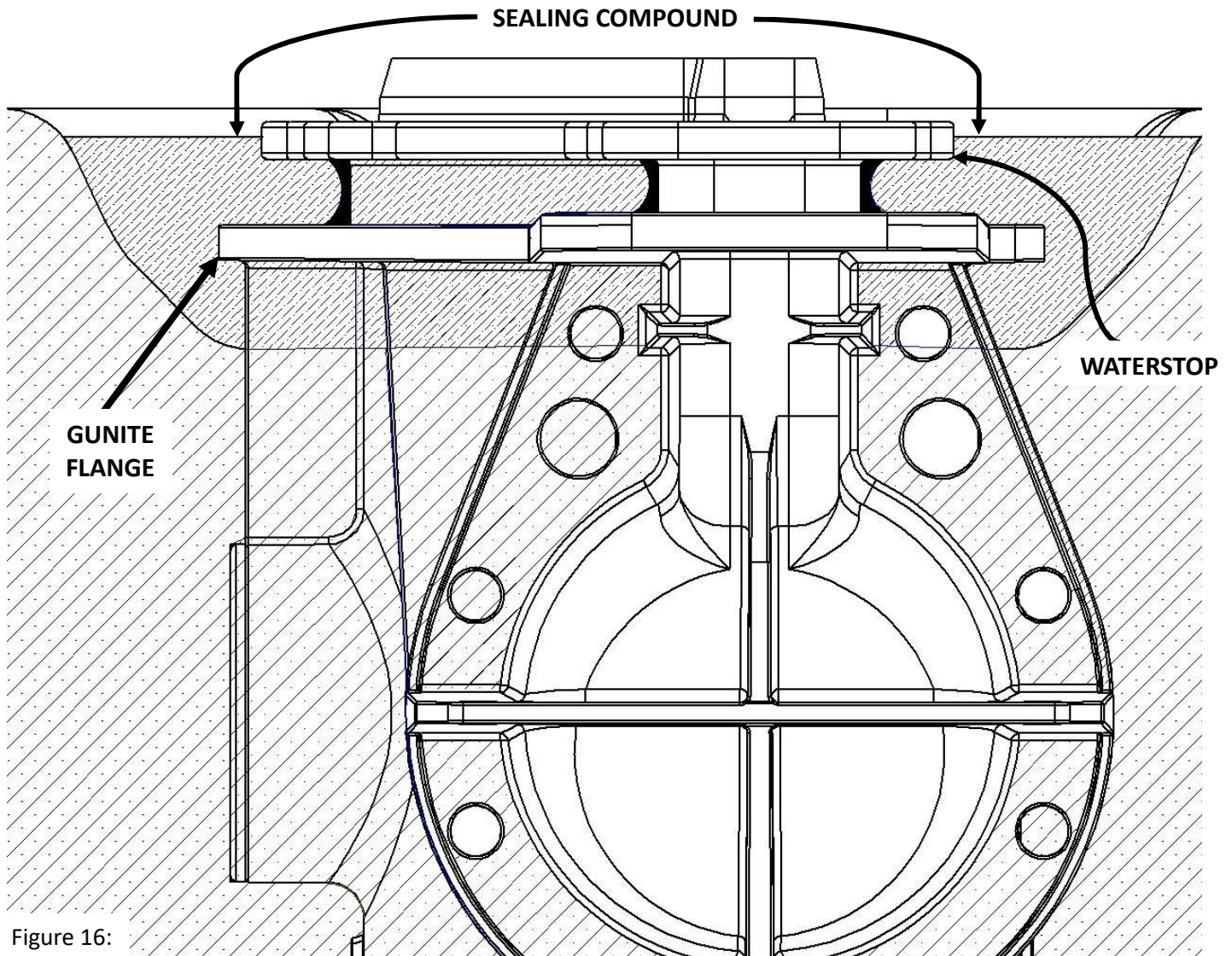

Examples of common sealing compounds include: Hydraulic Cement, Topping Mix Cement, Thoro Acryl®60 by ChemRex® or equivalent.

pulcollekt_LD1

INTERIOR FINISH INSTALLATION

Install the interior finish as normal. Packing the finish tightly around the entire drain opening to ensure a water-tight seal. The pool finish should be flush with the top finish edge of the drain (Fig. 17)

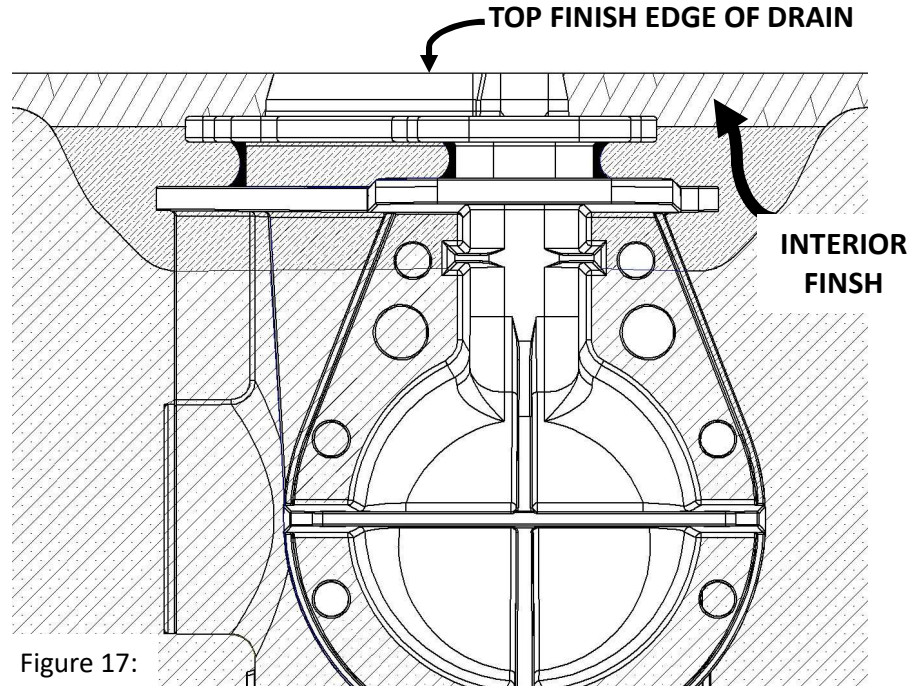

Figure 17:

The pre-installed fillable Cap is designed to be filled at the same time as the pool interior and should be filled flush to the upper edge. (Fig. 18)

The Cap can be flipped over to reveal a solid plastic side for those not wanting to match the interior finish. After interior finish, complete any curing or acid washing processes prior to moving to the next step. (Fig. 19)

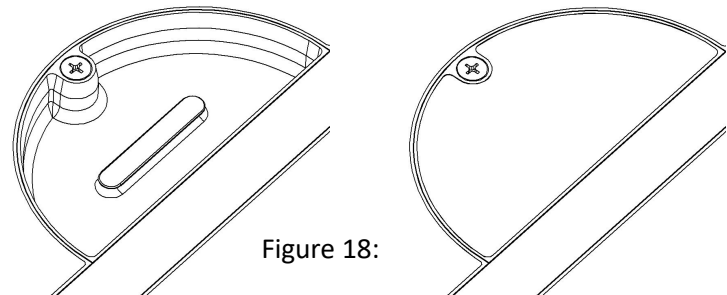

Figure 18:

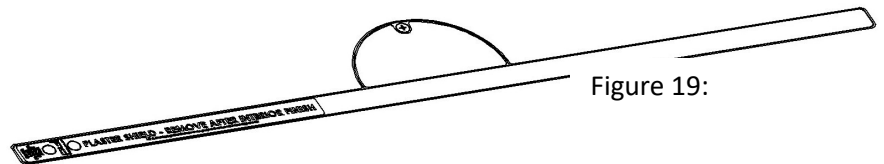

Figure 19:

pulcollekt_LD1

PLASTER SHIELD & CAP REMOVAL

Prior to filling the pool, the installer must first remove the Plaster Shield and Pressure Plug. Pulling up on the edge of the label included with the plaster shield will reveal two removal holes in the foam. **(Fig. 20)**

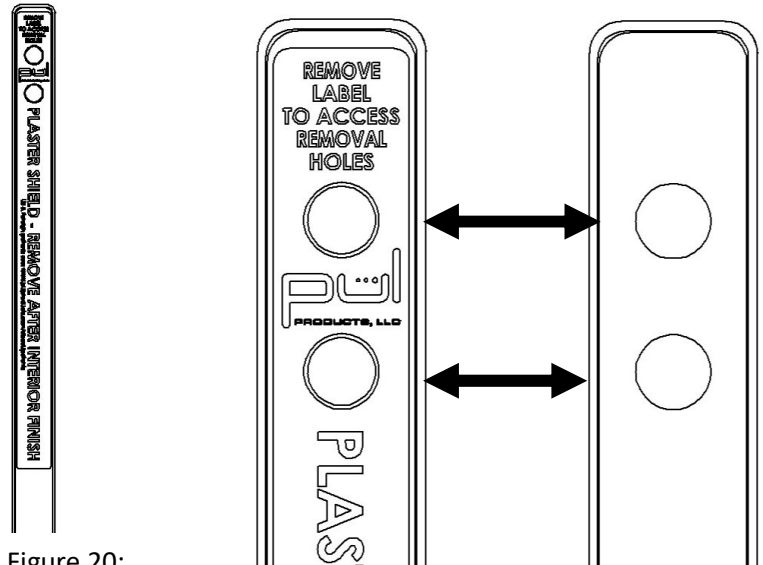

Figure 20:

Use the removal holes to pull up on the Plaster Shield removing it from the drain body. **(Fig. 21)**

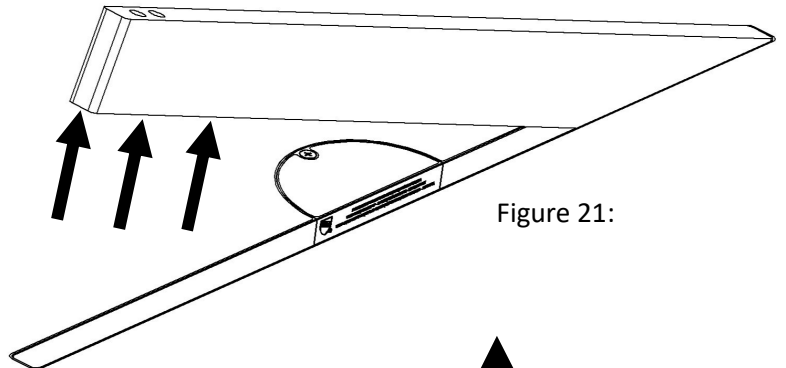

Figure 21:

Using a manual Philips screwdriver, loosen and remove the screw securing the Cap. Slide the Cap inward and lift to remove the Cap from the drain body to reveal the Pressure Plug. **(Fig. 22)**

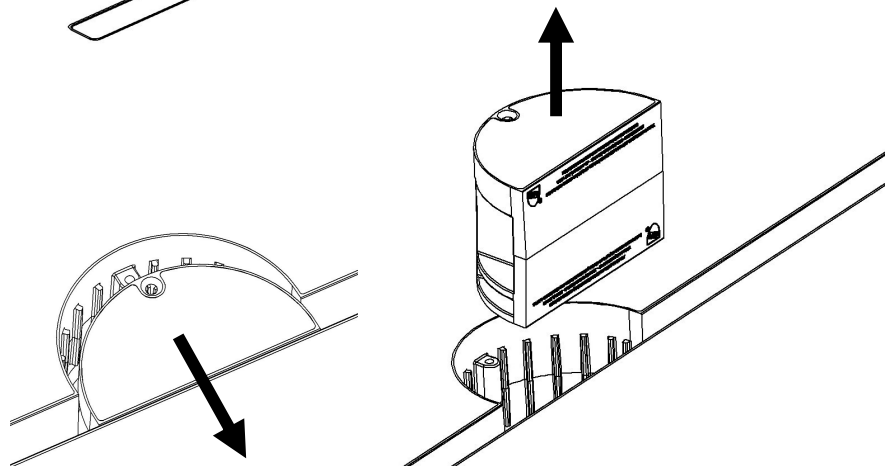

Figure 22:

pulcollekt_LD1

PRESSURE PLUG REMOVAL

Prior to removal of the Pressure Plug verify that all pressure has been released from the plumbing system.

Failure to release system pressure could result in severe injury when removing the Pressure Plug.

Unscrew and remove the plug **ensuring that you also remove the sealing gasket** & save for winterization. (Fig. 23)

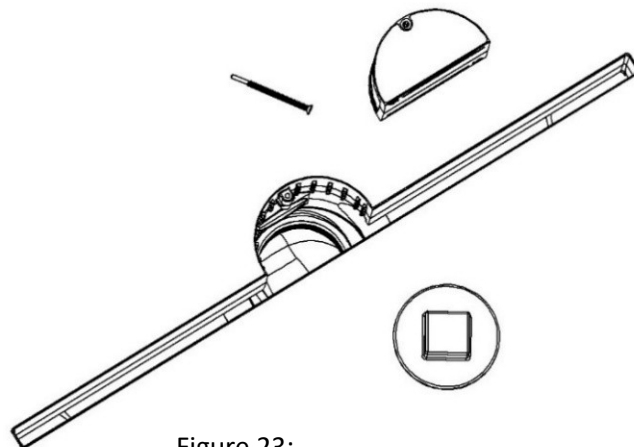

Figure 23:

Reinstall the Cap using the original screw & tighten by hand – **NO POWER TOOLS!**

WALL / VERTICAL INSTALLATION

The PULCollekt_LD1 drain has been certified for installation in the wall of a pool. The drain must be installed in the orientation shown (With the Cap on top. (Fig. 24)

The installation process defined in the floor instructions should be followed for wall installation as well. However, there are a few minor differences:

1. **Fill all voids surrounding the Drain.**
Failure to pack in all voids surrounding the drain may result in leaks in the finished pool.
2. The upper edge of the drain will define the finish surface of the wall.
3. The LD1 Body must be installed at a minimum of 24" from the floor of the pool & a minimum of 24" from the water line.
4. Use a torpedo level or similar to ensure that the drain slot is level and parallel to the pools tile & water lines.

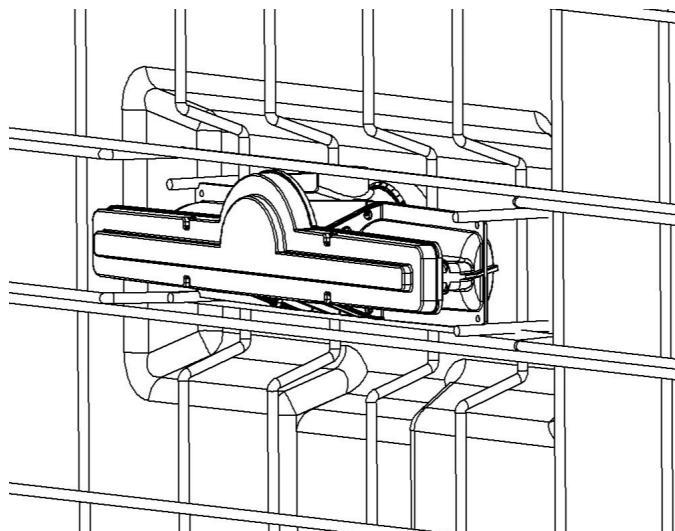
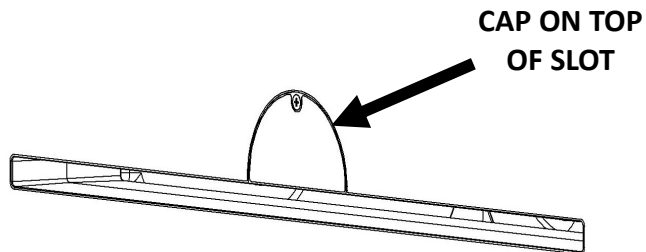

Figure 24:



pulcollekt_LD1

WATER VELOCITY CALCULATIONS

The PULCollekt_LD1 drain has been designed to provide maximum flow rate while minimizing water velocity. The two most restrictive areas (highest water velocity) in the drain are the opening slot and the 4" outlet at the bottom of the drain.

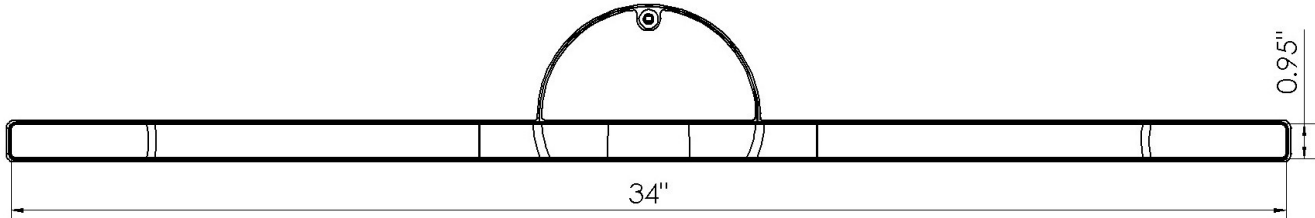

The opening slot dimensions are **34" x 0.95"** or a total surface area of **32.3 sq.in.** At the PULcollekt_LD1's maximum certified flow rate of 256GPM the water velocity passing through the opening slot is **2.5 ft./sec.**

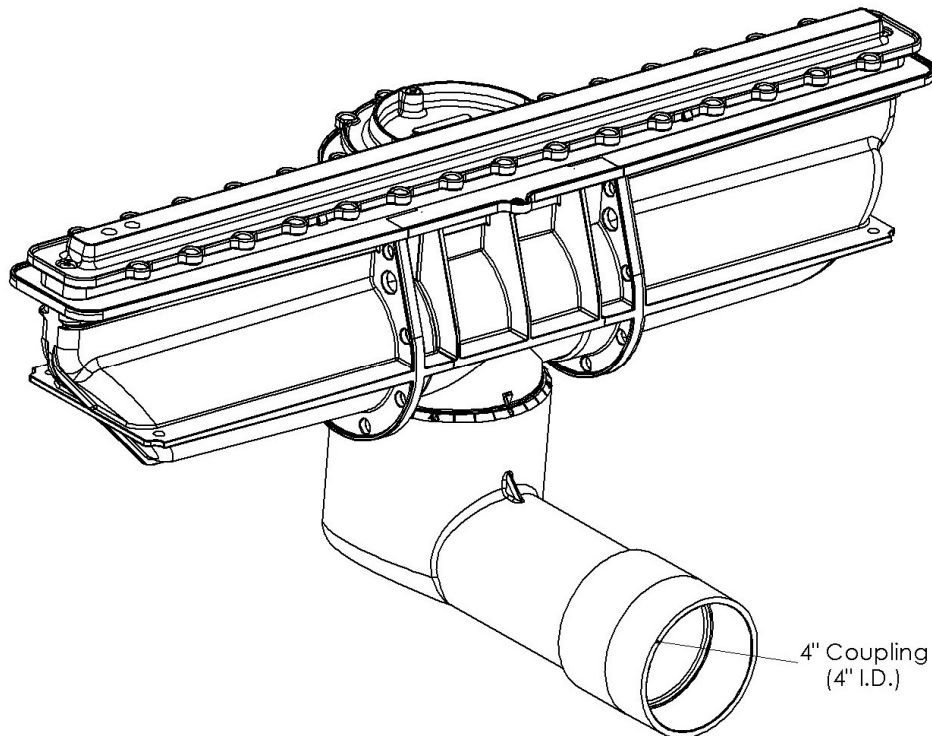

The 4" Outlet of the PULcollekt_LD1 is identical to a 4" schedule 40 pipe. The inside diameter is **4"** or **12.5sq.in.**

At the maximum certified flow rate of 256GPM the water velocity passing through the 4" outlet is **6.54 ft./sec.**

IAPMO RESEARCH AND TESTING, INC.

5001 E. Philadelphia Street, Ontario, CA 91761-2816 • (909) 472-4100 • Fax (909) 472-4244 • www.iapmort.org



CERTIFICATE OF LISTING

IAPMO Research and Testing, Inc. is a product certification body in which its product certification system includes inspection and testing of samples taken from the supplier's stock or from the market or a combination of both to verify compliance to the requirements of applicable codes and standards. This activity is coupled with periodic surveillance of the supplier's factory and/or warehouses as well as the assessment of the supplier's Quality Assurance System. This listing is subject to the conditions set forth in the characteristics below and is not to be construed as any recommendation, assurance or guarantee by IAPMO Research and Testing, Inc. of the product acceptance by Authorities Having Jurisdiction.

Issued to:

PUL PRODUCTS LLC

503 E. WATKINS ST.
PHOENIX, AZ 85004

Product:

Suction Outlet Fitting Assemblies (SOFA) for Use in Pools, Spas, and Hot Tubs

Products are in compliance with the following code(s):

Uniform Swimming Pool, Spa and Hot Tub Code (USPC®)

Products are certified to the following standard(s):

ANSI/APSP/ICC-16 2017 (PA 2021)

File Number: W-16298

Effective Date: March 2024



Revised Date: November, 15
2024

Void After Date: March 2029*

Chairman, Product Certification Committee

Chief Technical Service Officer

* This certificate is not evidence of current listing. To verify listing status, visit the IAPMO R&T Product Listing Directory at pld.iapmo.org

This listing period is based upon the last date of the month indicated on the Effective Date and Void After Date shown above. Any change in material, manufacturing process, marking or design without having first obtained the approval of the Product Certification Committee, or any evidence of non-compliance with applicable codes and standards or of inferior workmanship, may be deemed sufficient cause for revocation of this listing. Production of or reference to this form for advertising purposes may be made only by specific written permission of IAPMO Research and Testing, Inc. Any alteration of this certificate could be grounds for revocation of the listing. This document shall be reproduced in its entirety.

IAPMO RESEARCH AND TESTING, INC.

CERTIFICATE OF LISTING



Issued To: PUL PRODUCTS LLC

File Number: W-16298

Product: Suction Outlet Fitting Assemblies (SOFA) for Use in Pools, Spas,
and Hot Tubs

Effective Date: March 2024

Revised Date: November, 15
2024

Void After: March 2029

This certificate is not evidence of current listing. To verify listing status, visit the IAPMO R&T Product Listing Directory at pld.iapmo.org

Identification:

Covers/Grate shall be permanently marked as follows with font size of at least 0.08-in. (2.03 mm) tall and in a manner so as to be visible after installation. The name, trade name or trademark of the manufacture, a distinctive part number, the type of service, "Blockable" or "Unblockable", the manufacturer specified service life in years, "VGBA ####" where #### indicates the year this standard was approved by the American National Standards Institute, wall and floor flow rating or "For Flow Rating See Instructions", and the USPC® certification mark®. Covers/Grate shall also be permanently marked with the date of manufacture, or period of manufacture not exceeding 1 month, in a manner so as to be visible before or after installation. Manufactured Sumps and Mud Frames shall be permanently marked as follows with font size of at least 0.08-in. (2.03 mm) tall and in a manner so as to be visible after installation but may be permitted to be hidden when cover/grate is installed. The name, trade name or trademark of the manufacture, a distinctive part number, the manufacturer specified service life in years. Manufactured Sumps and Mud Frames shall also be permanently marked with the date of manufacture, or period of manufacture not exceeding 1 month, in a manner so as to be visible after installation but may be permitted to be hidden when cover/grate is installed. Self-Contained spa SOFA cover/grate shall also be marked with "For Use in Self-Contained Factory-Manufactured Spas only"

Characteristics:

Suction Outlet Fitting Assemblies (SOFAs) to be fully submerged for use in swimming pool, hot tubs, spas, portable spa or non-portable wading pool or other aquatic venue intended for swimming or recreational bathing. RDP SOFAs with field-built sumps, fabricated in situ at an aquatic facility, are to be installed in accordance with the cover/grate manufacturer's installation instructions, and in accordance with the certified plans of a registered design professional. To be installed in accordance with the manufacturer's instructions and the latest edition of the USPC®. Products that meet the requirements of ANSI/APSP/ICC-16 2017 are also considered in compliance with 16 CFR 1450.

Products listed on this certificate have been tested by an IAPMO R&T recognized laboratory. This recognition has been granted based upon the laboratory's compliance to the applicable requirements of ISO/IEC 17025.

IAPMO RESEARCH AND TESTING, INC.

CERTIFICATE OF LISTING



Issued To: PUL PRODUCTS LLC

Effective Date: March 2024

File Number: W-16298

Revised Date: November 15, 2024

Product: Suction Outlet Fitting Assemblies (SOFA) for Use in Pools, Spas, and Hot Tubs

Void After Date: March 2029

This certificate is not evidence of current listing. To verify listing status, visit the IAPMO R&T Product Listing Directory at pld.iapmo.org

Product Type Fittings
NOTE Product comes in both grey and white

Brand Name	Model Number	Description
PUL Products LLC	2205-00001A-01-XX ^{1,2}	Submerged suction outlet for installation as a single unblockable drain or in a multi-drain system. (4" pipe) (Maximum flow - 256 GPM Floor & Wall)

¹ XX = DG for dark grey or W for white.

² Model numbers can be represented as CLD-BO-01-DG or CLD-BO-01-W.