

pulreturn_LR1

Adjustable – Unsealed

PUL Return_LR1 Installation Instructions and Owner's Manual

ATTENTION

Installers must read and follow these instructions. Once complete provide these instructions to the facility owner to keep for further reference. Follow all codes and regulations that apply to the design, installation, and use of return outlet fittings.

WARNING

The PUL Products Return LR1 System must be installed in accordance with PUL's written instructions manual, and in conformity with applicable Federal, State, Local, and Swimming pool industry building and safety codes.

The PULreturn_LR1 is only to be installed as a return fitting.

NEVER CONNECT THE PUL RETURN LR1 TO A SOURCE OF SUCTION!

IMPORTANT SAFETY INSTRUCTIONS: PLEASE REVIEW THE OWNER'S MANUAL AND INSTALLATION INSTRUCTIONS IN ITS ENTIRETY AND HEED ALL SAFETY INFORMATION. Failure to follow these instructions and warnings can result in DEATH OR SERIOUS INJURY.

PUL Products LLC – 503 E Watkins St – Phoenix, AZ 85004

Phone: (833) 922 – 2418

info@pulproducts.com – www.pulproducts.com

US & Foreign patents and patents pending see www.pulproducts.com/about/patents/.

pulreturn_LR1

INCLUDED COMPONENTS

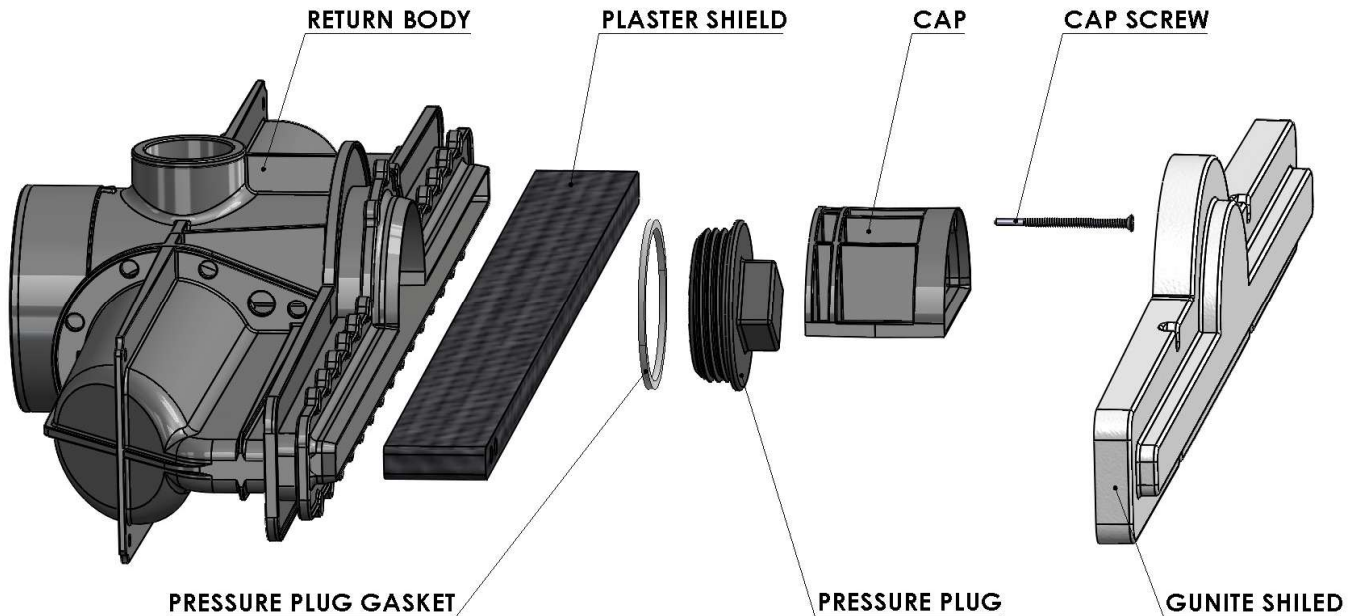

Figure 1:

DESCRIPTION	PART #
COMPLETE RETURN ASSEMBLY	2305-20002A-01
GUNITE SHIELD	2205-20013A-01
CAP SCREW	2205-80002A-01
FLIP CAP	2205-20007A-01
PRESSURE PLUG	2205-20009A-01
PRESSURE PLUG GASKET	2205-40018A-01
PLASTER SHIELD	2205-20017A-01

pulreturn_LR1

INSTALLATION:

Installation of PUL Products Return LR1 System must be performed by a properly trained certified contractor following the exact installation instructions defined in this document.

The top surface of the PUL Return LR1 defines the side/bottom of the pool's interior finish. The LR1 body must be installed at a minimum of 24" from the floor of the pool & a minimum of 24" from the water line.

ATTENTION:

Care must be taken to ensure that the entire return fitting is fully packed on all sides with Gunite to provide proper sealing and support. Fully pack in the entire return with Gunite up to 1" below the Gunite Flange & fully pack Waterproof Sealant (Hydraulic Cement or similar) from the underside of the Flange Shield to the underside of the Water Stop, as shown in Figure 2 below. Failure to properly pack in this material may result in leaks and/or failure of the interior finish.

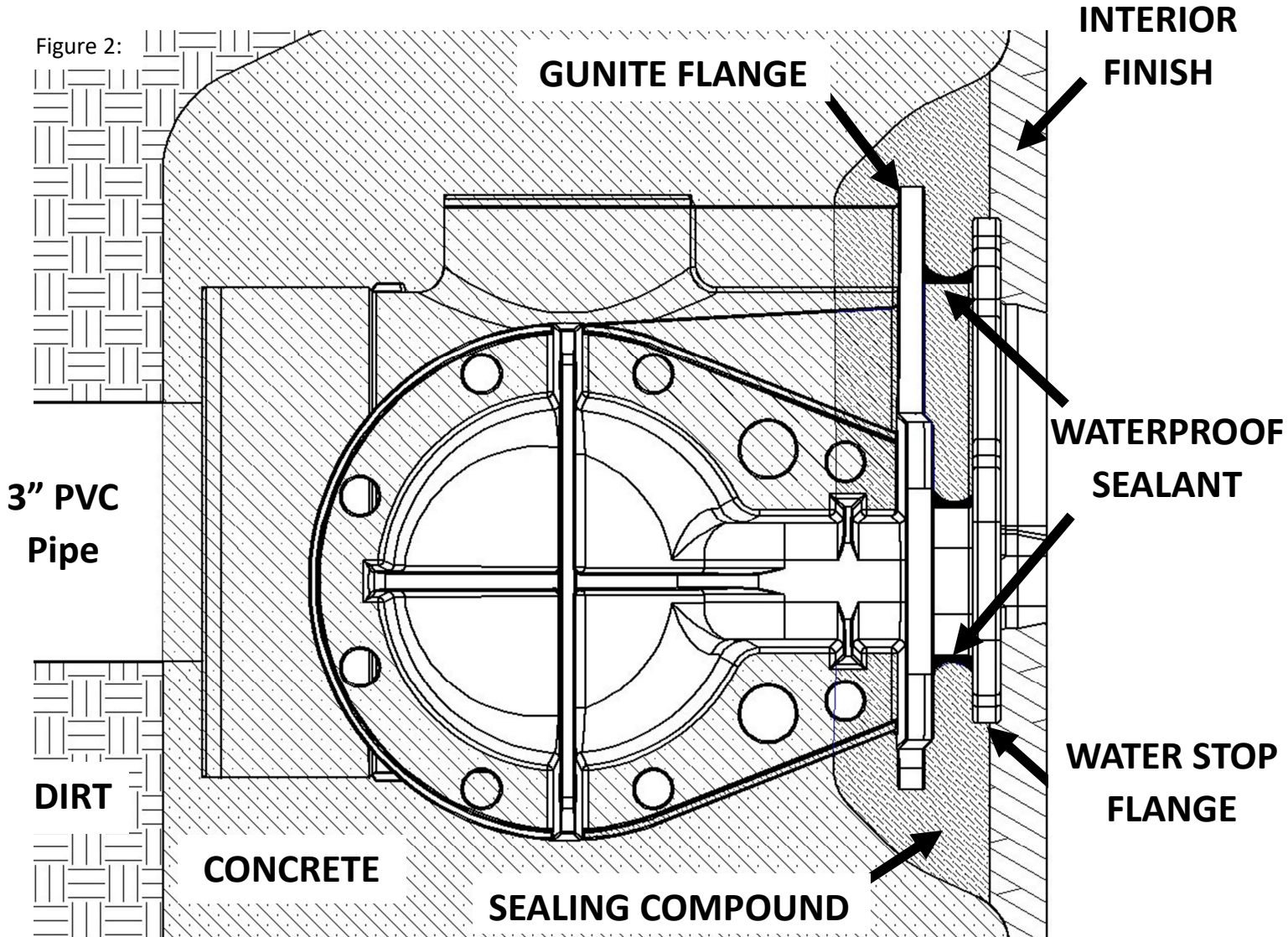

pulreturn_LR1

FASTENERS:

All fasteners included with the PUL Return LD1 come preinstalled into the assembly.

Only the supplied fasteners should be used. Use of any alternate fasteners is prohibited.

START ALL FASTENERS BY HAND TO ENSURE PROPER THREAD ENGAGEMENT

DO NOT USE POWER TOOLS – HAND TOOLS ONLY

Removal of fasteners during pressure plug removal or winterization is acceptable but only the original or manufacturer supplied replacement fasteners may be used during reinstallation.

The **use of adhesives** to secure or repair any portion of the return is **strictly prohibited**.

EXCAVATION & CONNECTING TO PLUMBING

Identify the location of the return in the wall or bottom of the pool, excavate the return location to provide space for the return & plumbing line.

WALL INSTALLATION SHOWN

The upper edge of the return will determine the depth or wall surface of the pool and the final location of the interior finish.

The round access port should be oriented on top of the drain as shown. This is especially critical when located near any horizontal surface below.

Verify that the return is level in the excavated area. (**Fig.3**)

Connect the pressure side plumbing, backfill the plumbing trench and pack the dirt around pipe to secure the return and maintain level.

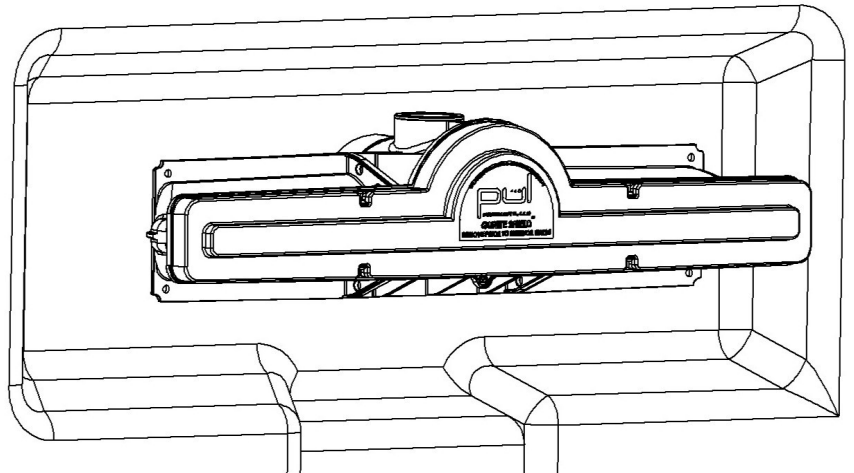

Figure 3:

ABS – PVC Transition Cement is REQUIRED for this connection - Weld-On 794 or Oatey Transitional Cements are recommended.

pulreturn_LR1

REBAR INSTALLATION & DRAIN TIE-IN

Lay the pool's rebar cage into the floor & wall of the pool as normal. The rebar must be bent into a basket shape and routed below & around the return. **(Fig. 4)**

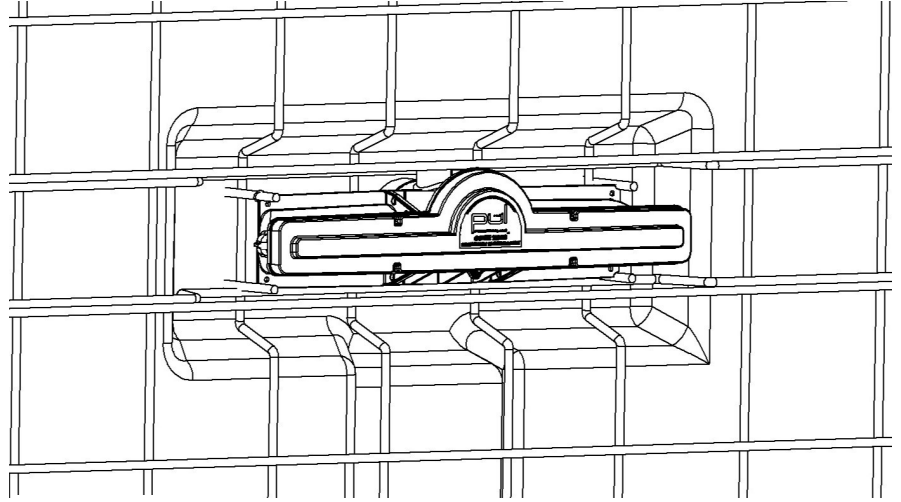

Figure 4:

The cage should be located halfway between the dirt excavation and the bottom of the return fitting. **(Fig. 5)**

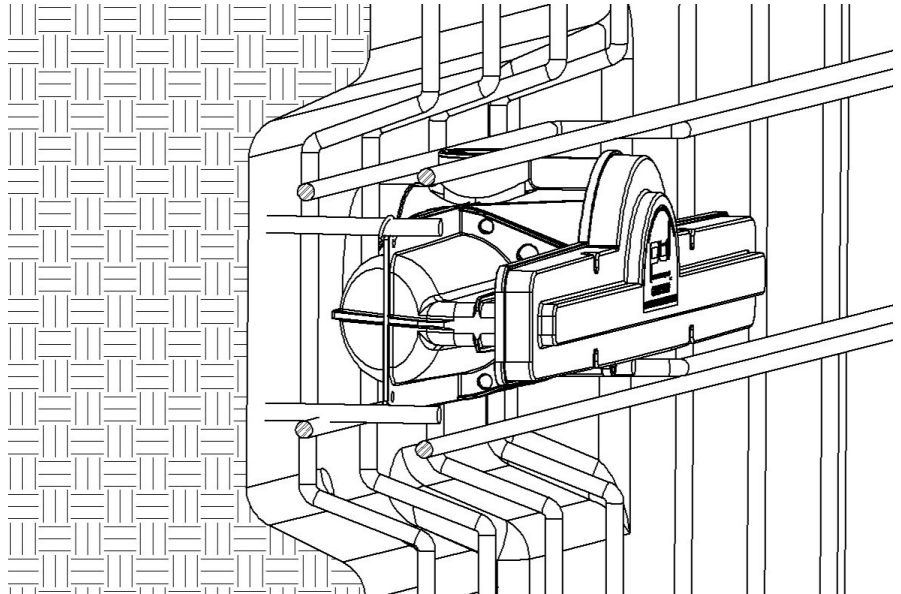

Figure 5:

pulreturn_LR1

GUNITE / SHOTCRETE INSTALLATION

Shoot the concrete shell of the pool as normal making sure to fill all voids surrounding the return and rebar cage.

Failure to completely pack in all the voids surrounding the Return may result in leaks in the finished pool.

The concrete should finish to approximately $\frac{1}{2}$ inch below the upper edge of the return opening. (**Fig. 6**)

Following concrete installation provide clearance around the entire Gunite Shield. The installer should be able to fit a finger between the Gunite Shield and the concrete down to the bottom & under edge of the shield / Gunite Flange as shown.

(**Fig. 7**)

Providing sufficient clearance is critical for proper sealing of the return, removal of the Gunite Shield and final trim adjustment prior to interior finish installation. (**Fig. 8**)

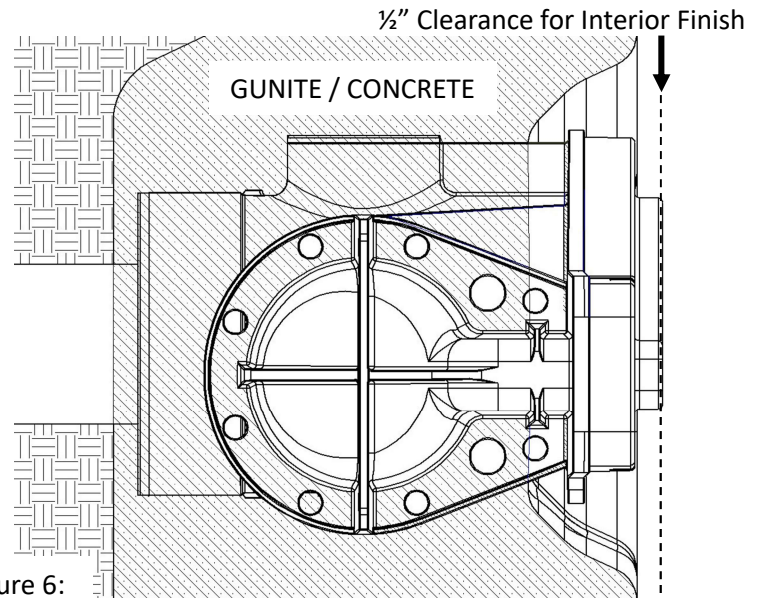

Figure 6:

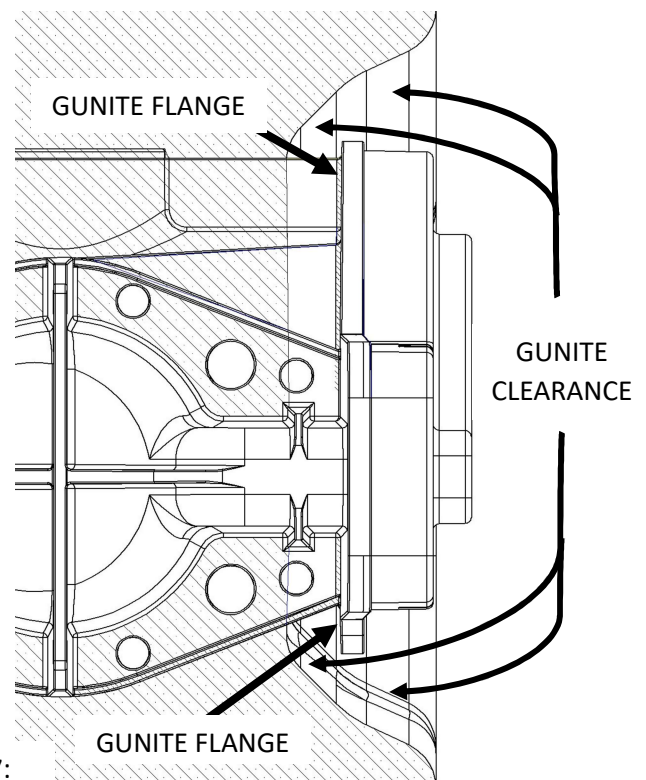

Figure 7:

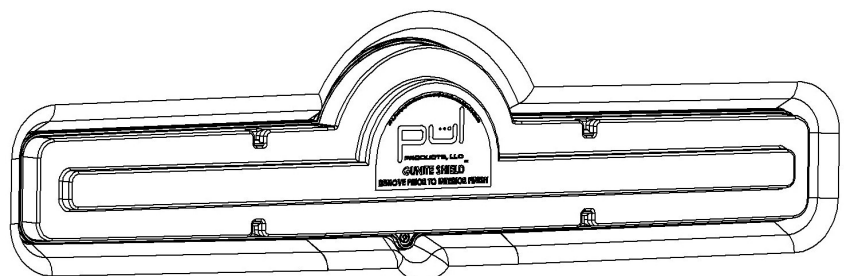

Figure 8:

pulreturn_LR1

ADJUSTABLE ANGLE UPPER GRATE

Each PULreturn_LR1 assembly has the ability to adjust the height and angle of the Upper Grate by up to 2 inches to accommodate any variations in the concrete shell and to fine tune the final height and angle of the interior finish.

These adjustments should be made at the time of pool interior finish installation.

To access the Height/Angle Adjustment Screws you must first remove the snap-on Gunite Shield to expose the top of the Upper Grate and the screws located at each end of the return assembly. **(Fig. 9)**

As you unscrew the Height/Angle Adjustment Screws the Upper Grate will lift increasing the angle from either side. **(Fig. 10)**

This adjustment is limited to 2". Unscrewing both Adjustment Screws will lift the entire Upper Grate, shallowing or narrowing the pool. **(Fig. 11)**

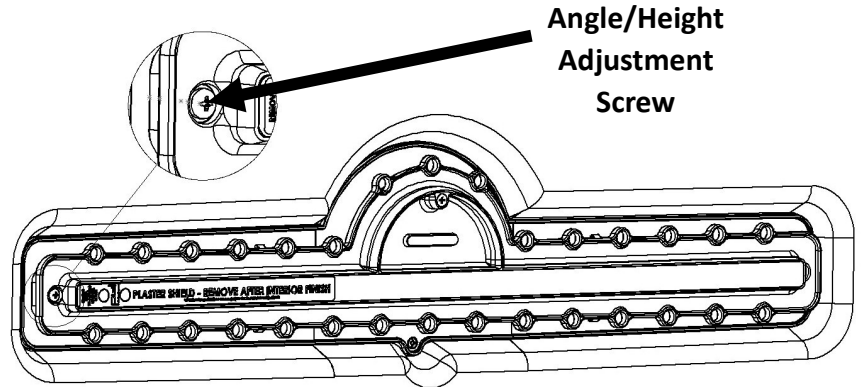

Figure 9:

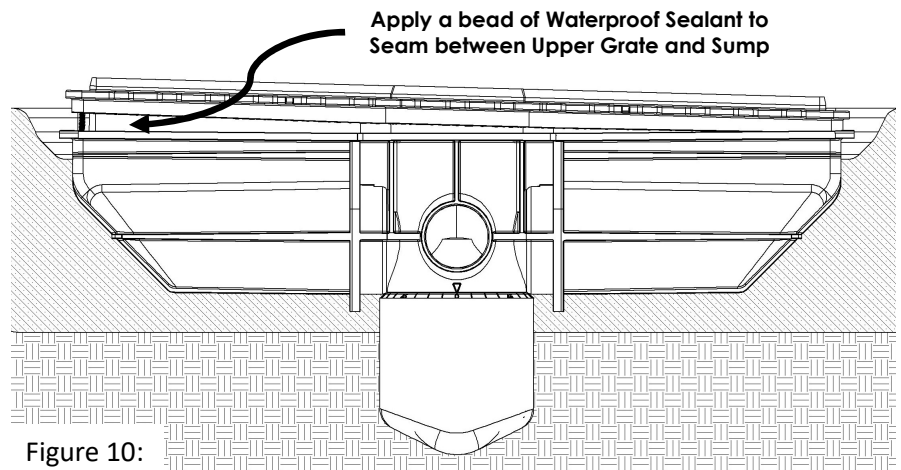

Figure 10:

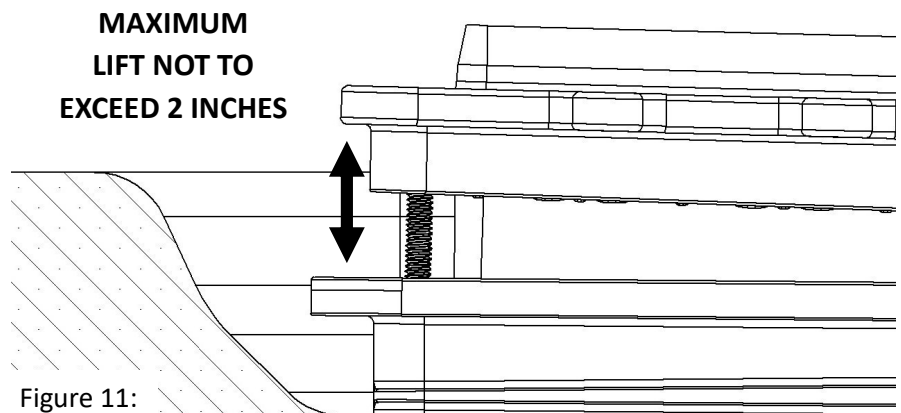

Figure 11:

pulreturn_LR1

Upper Grate Sealing Procedure

Proper sealing of the PULreturn_LR1 is critical in ensuring that the installation is leak free. The following procedure will define the necessary steps required to ensure that the installation is trouble-free.

A simple video of the sealing process, in both English and Spanish, can be viewed by scanning the QR codes provided.

ENGLISH



SPANISH



STEP #1: Using the angle adjustment screws located on top of the Upper Grate raise both ends ~1" (**Fig.12**).



Figure 12:

STEP #2: Apply a 3/8" – 1/2" bead of SikaFlex Construction Sealant to the entire perimeter of the exposed vertical face of the Upper Grate as shown (**Fig. 13**).



Figure 13:

STEP #3: Ensure that sufficient sealant is applied to the short ends of the Upper Grate around the Adjustment screws as shown (**Fig. 14**).

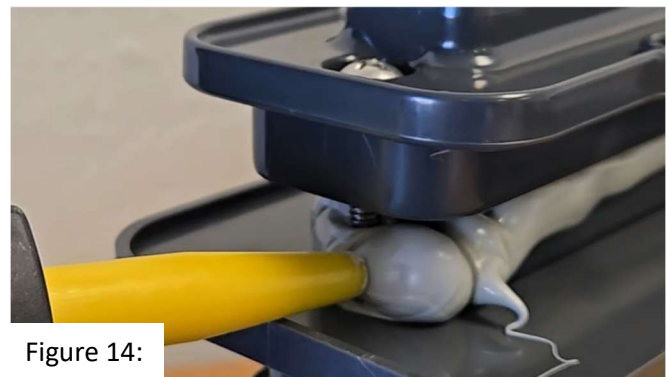

Figure 14:

pulreturn_LR1

STEP #4: Using the angle adjustment lower the Upper Grate onto the Sump. There should be a bead of sealant extruded from the entire perimeter of the seam between the Upper Grate & Sump as shown (**Fig.15**).



Figure 15:

STEP #23: If the angle adjustment feature is required to level the Upper Grate, make the necessary adjustments to level the upper Grate (**Fig. 16**).



Figure 16:

STEP #6: Apply additional sealant to the void created by raising the Upper Grate to ensure a watertight seal (**Fig. 17**).



Figure 17:

STEP #7: Perform a “Finger Swipe” around the entire perimeter of the drain to remove excess sealant as shown (**Fig. 18**).

Allow sealant to cure prior to moving on to the next step.



Figure 18:

pulreturn_LR1

SEALING COMPOUND

Use an approved sealing compound to fill the space below the Water Stop and Guniting Flange.

Ensure that all the space below the Guniting Flange and Water Stop are tightly packed without any voids (As Shown) to ensure a water-tight seal. (Fig. 19)

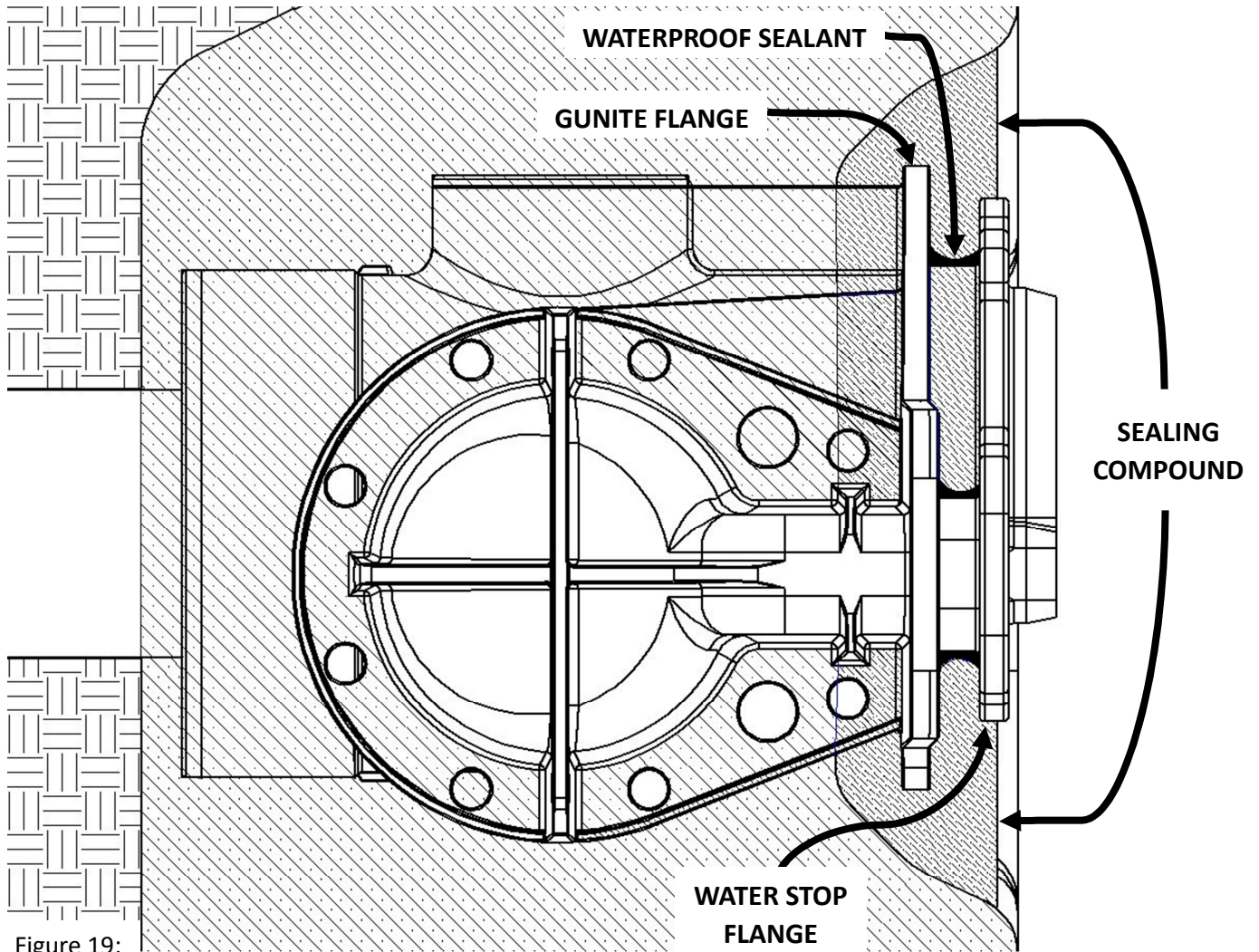

Figure 19:

Examples of common sealing compounds include: Hydraulic Cement, Topping Mix Cement, Thoro Acryl®60 by ChemRex® or equivalent.

pulreturn_LR1

INTERIOR FINISH INSTALLATION

Install the interior finish as normal. Pack the finish tightly around the entire return opening to ensure a water-tight seal. The pool finish should be flush with the top finish edge of the return. **(Fig. 20)**

The pre-installed fillable Cap is designed to be filled at the same time as the pool interior and should be filled flush to the upper edge. **(Fig. 21)**

The Cap can be flipped over to reveal a solid plastic side for those not wanting to match the interior finish.

After interior finish, complete any curing or acid washing processes prior to moving to the next step. **(Fig. 22)**

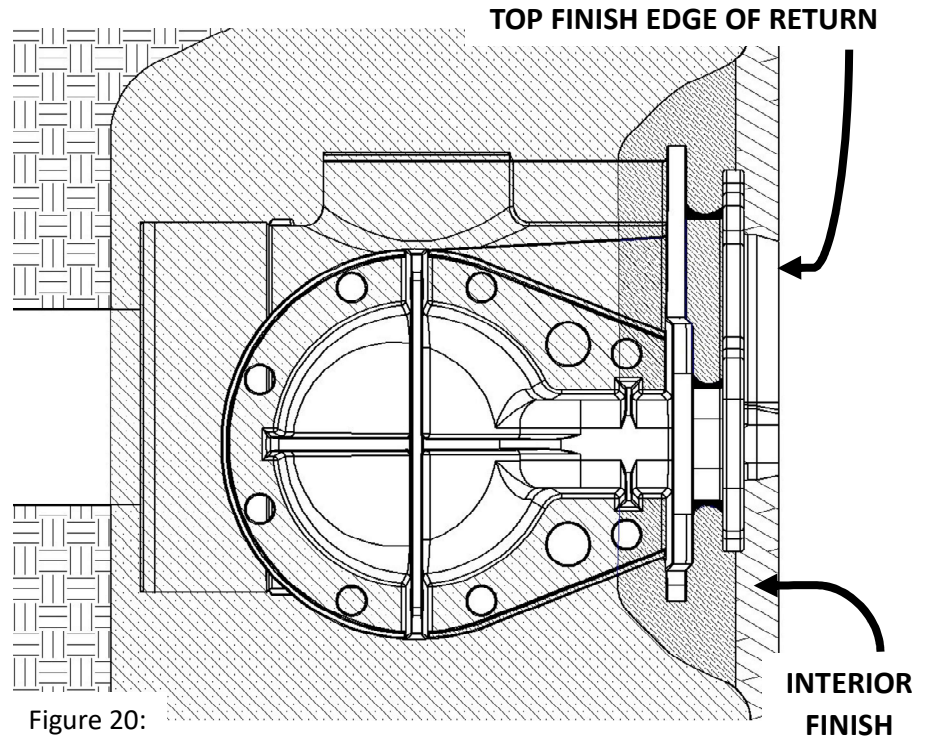

Figure 20:

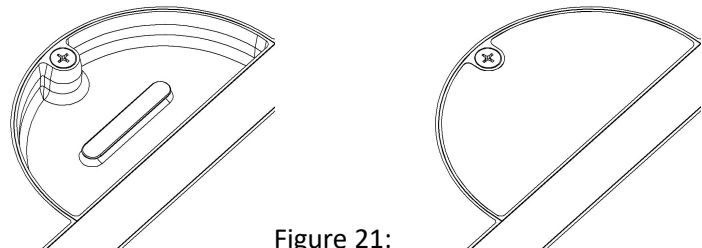

Figure 21:

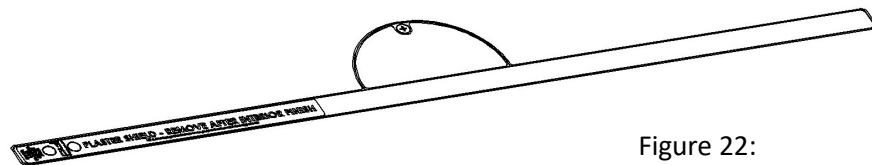

Figure 22:

pulreturn_LR1

PLASTER SHIELD & PRESSURE PLUG REMOVAL

Prior to filling the pool, the installer must first remove the Plaster Shield and Pressure Plug.

Pulling up on the edge of the label included with the plaster shield will reveal two removal holes in the foam. (**Fig. 23**)

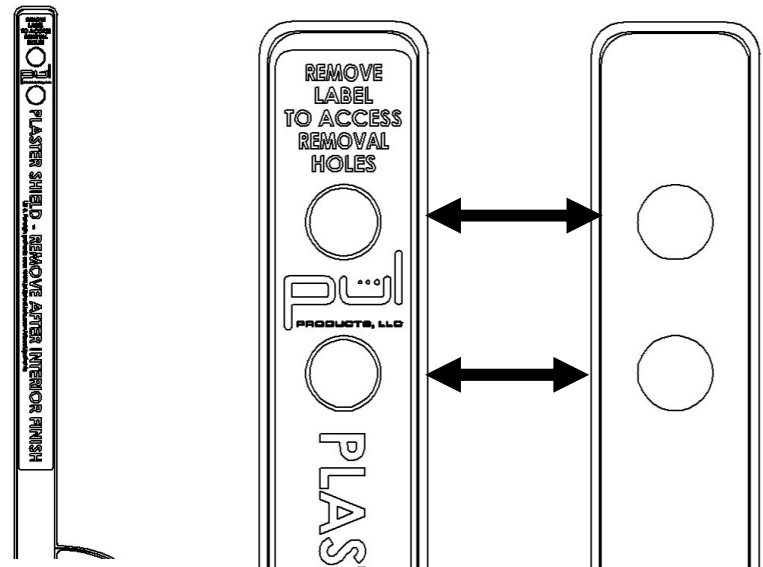

Figure 23:

Use the removal holes to pull up/out on the Plaster Shield removing it from the return body. (**Fig. 24**)

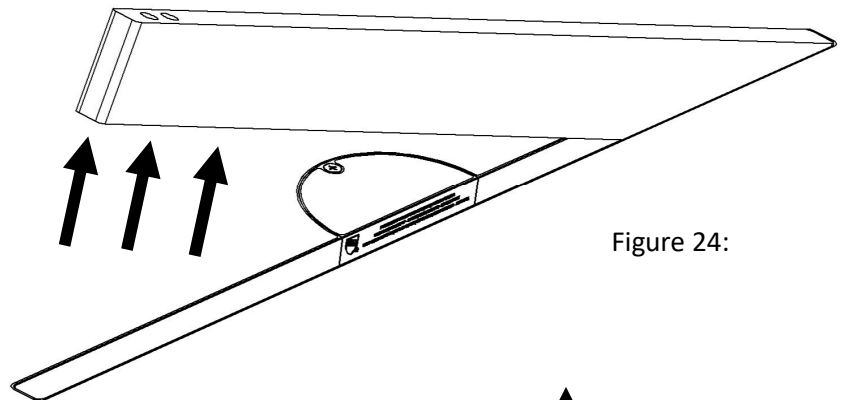

Figure 24:

Using a manual Philips screwdriver, loosen and remove the screw securing the Cap. Slide the Cap inward and lift to remove the Cap from the return body to reveal the Pressure Plug.

(**Fig. 25**)

Loosen by hand – **NO POWER TOOLS!**

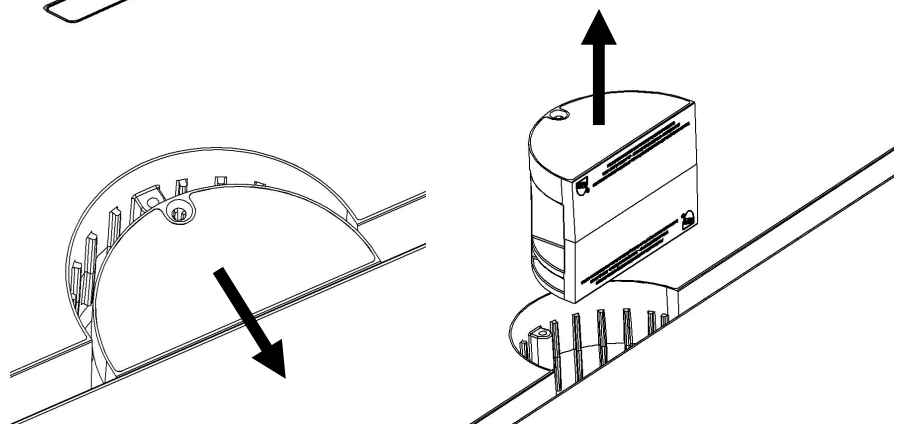

Figure 25:

pulreturn_LR1

PRESSURE PLUG REMOVAL

Prior to removal of the Pressure Plug verify that all pressure has been released from the plumbing system.

Failure to release system pressure could result in severe injury when removing the Pressure Plug.

Unscrew and remove the plug & save for winterization.

Reinstall the Cap using the original screw & tighten by hand – **NO POWER TOOLS!**

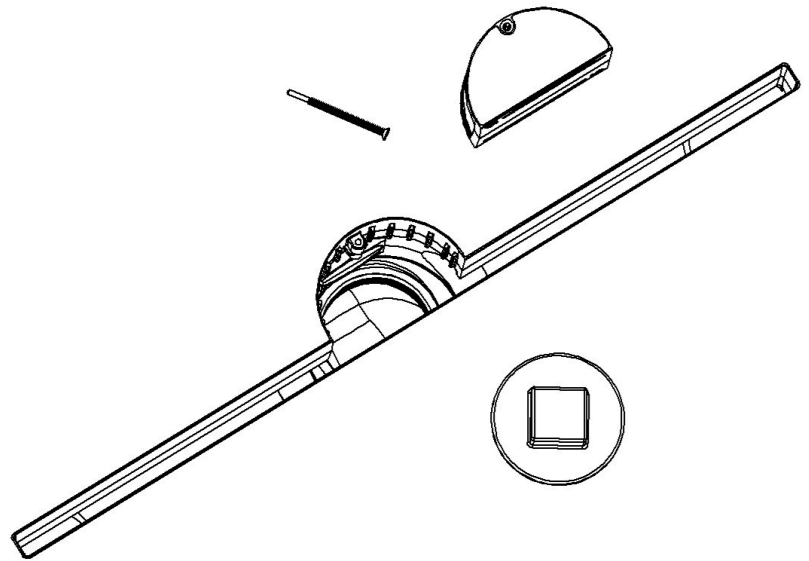

PULreturn_LR1 DIMENSIONS

